

AU-D33|D22 TU-S33

Sansui Super-Feedforward DC Amplifiers & Servo-Lock Tuner.



A Trio of Popularly-Priced Components Incorporating Top-of-the-Line Circuitry and Features.

It's the top-of-the-line models in any manufacturer's lineup that normally sport the very latest—and best—technology and features. This is true of Sansui. Our new top-of-the-line AU-D11 and AU-D9 integrated amplifiers each employ highly acclaimed Super Feedforward circuitry. But at Sansui, we've made it possible for anyone to afford this very same high technology with the introduction of two new competitively-priced integrated amplifiers, models AU-D33 and AU-D22. Both display almost the same, virtually distortion-free performance of our very best models, and share many other features like MC cartridge capability and versatile control functions. In fact, the only real difference you'll find is power output. Yet both the AU-D33 and AU-D22 are priced no higher than competitor's models in the same power ranges.

You'll find that the matching TU-S33 Servo-lock tuner is also designed for state-of-the-art performance fully on a par with far more expensive models. We invite you to compare any of these new Sansui components with any other hi-fi components on the market. Each is available in your choice of black or silver finish.

THE END

Super

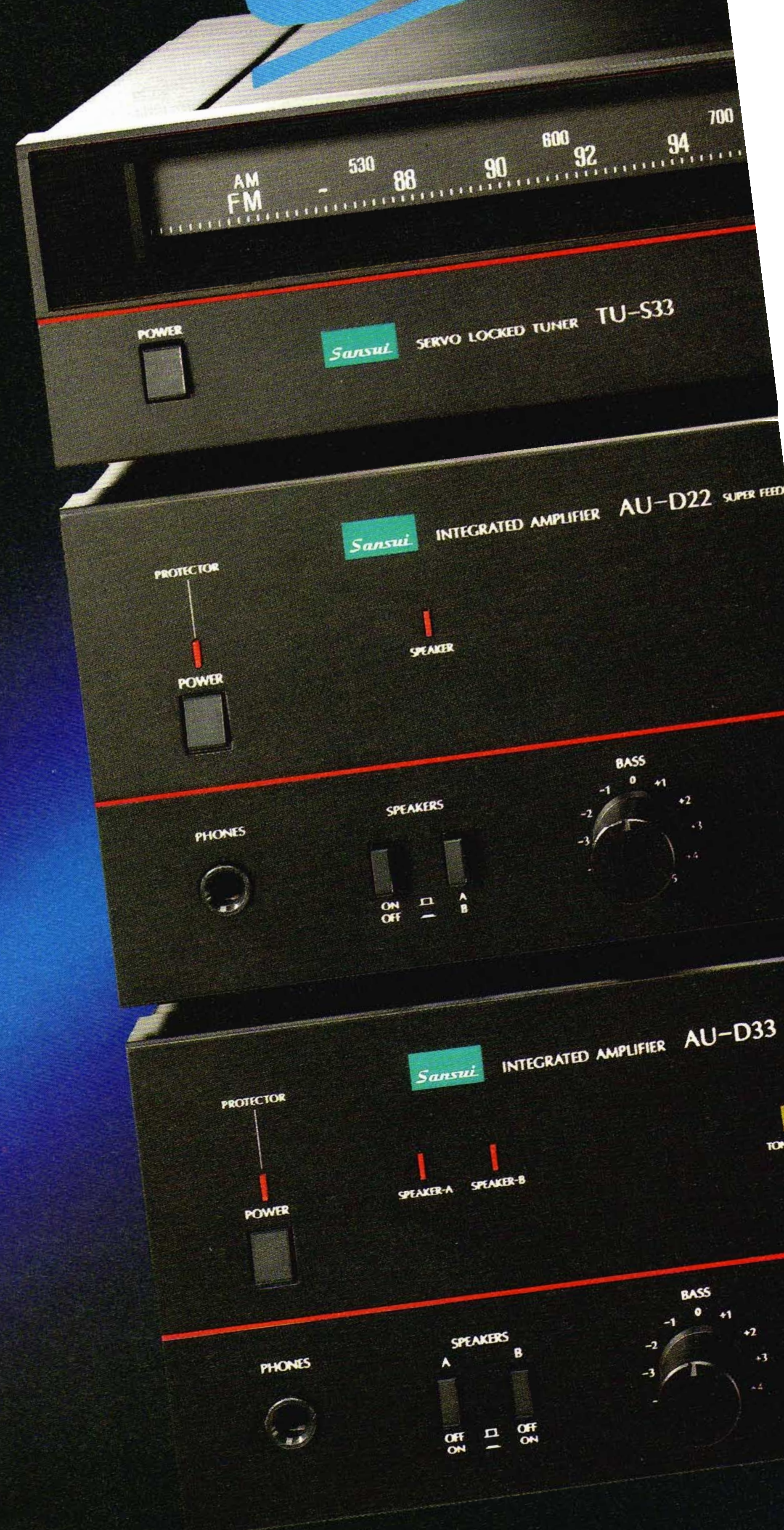

Audio Cabinet GX-155

The AU-D33 and AU-D22— The Super Feedforward Amplifiers That Sound Great.

The Super Feedforward System has reduced distortion levels to the point where they're barely measurable

In a nutshell, our Super Feedforward System (pat. pend.) combines common negative feedback circuitry with the feedforward technique in the power amplifier section.

Negative feedback essentially reduces distortion in the low to mid frequency ranges, while feedforward alleviates distortion in the high frequency range. Together they keep distortion low across an ultra-wide range. When we say distortion, we're not speaking merely of harmonic distortion. Our Super Feedforward System reduces or entirely eliminates every conceivable type of distortion that a power output stage generates—intermodulation, switching, crossover, transient intermodulation (TIM), envelope, and so forth. When you listen to either the AU-D33 or AU-D22, you'll notice an unusual stability and clearness that is lacking in amplifiers that rely on negative feedback alone to combat distortion.

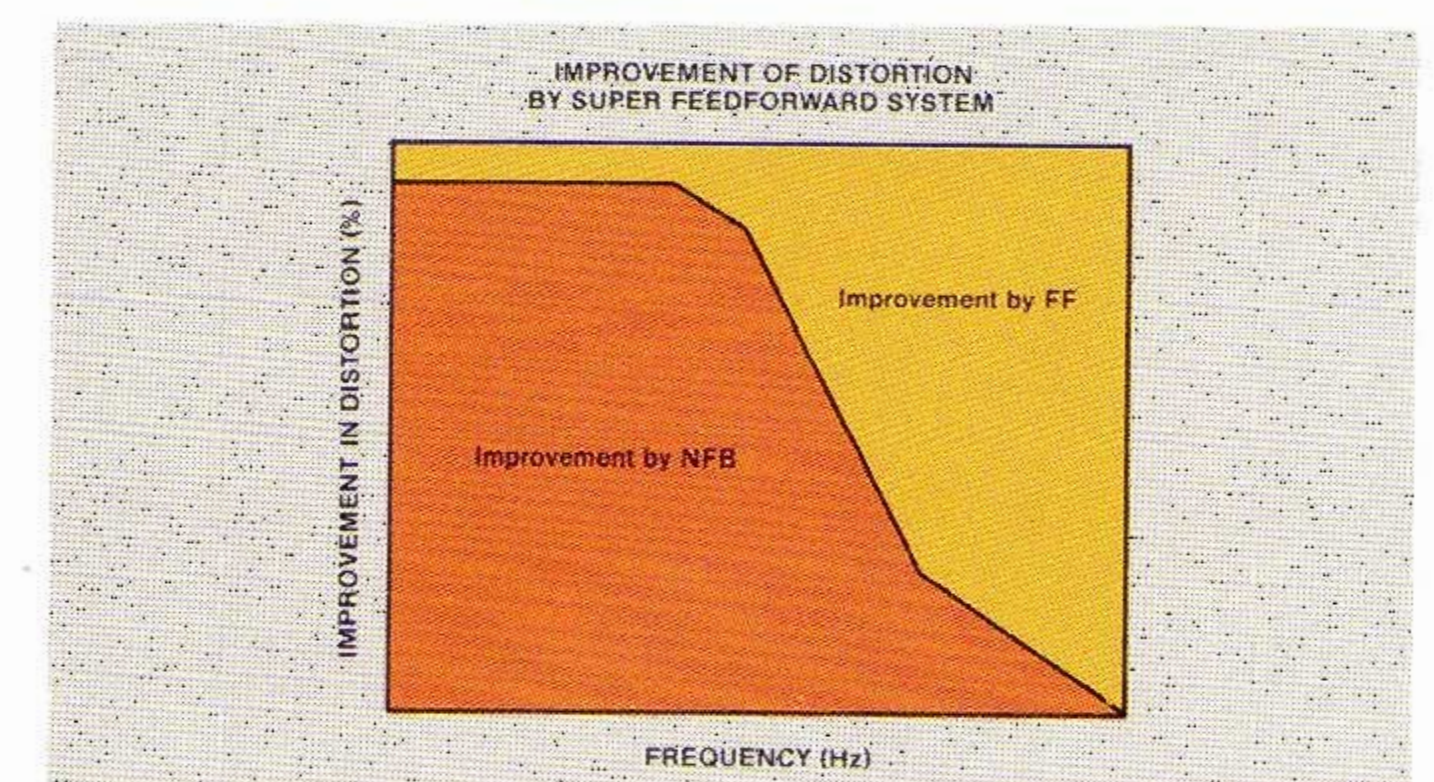
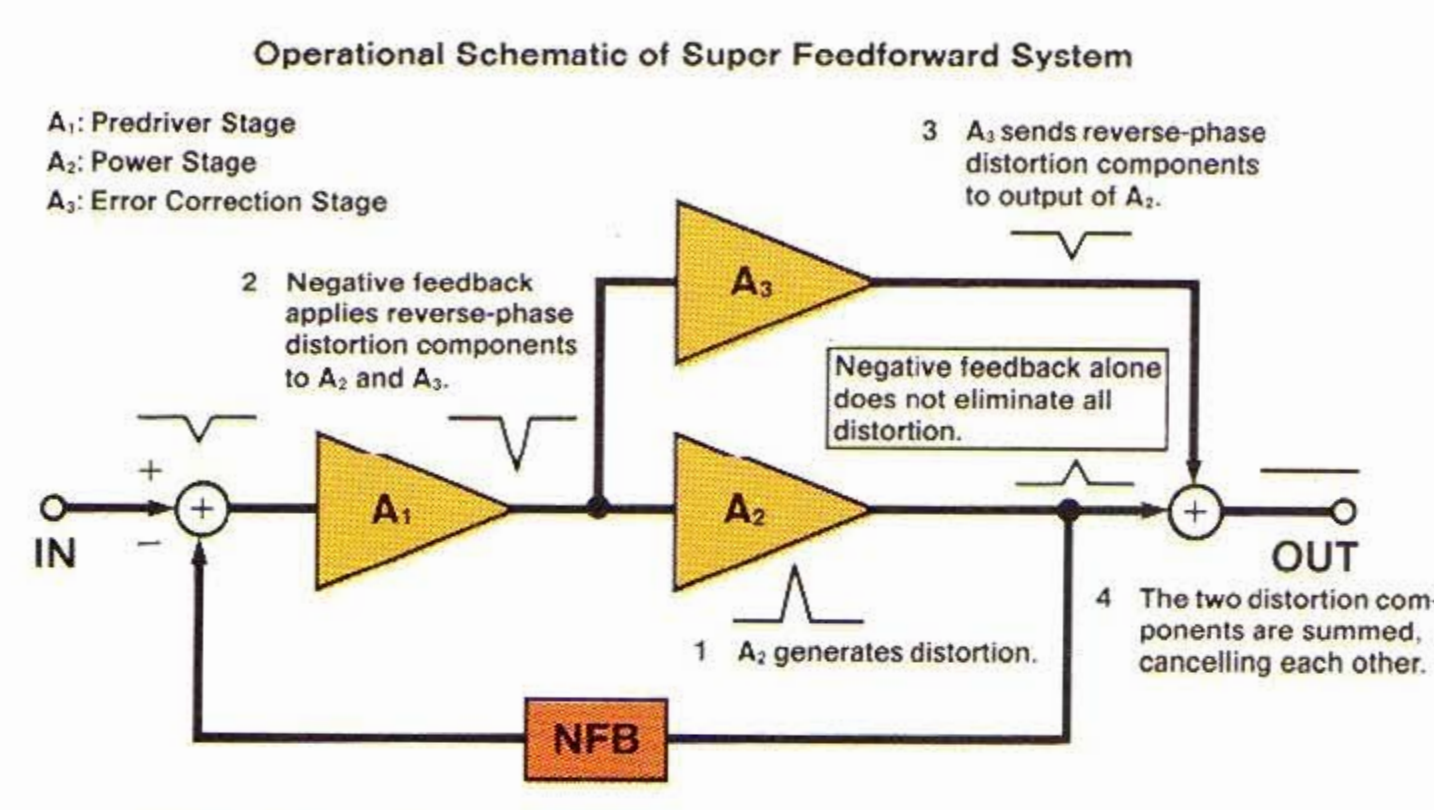

The Super Feedforward System goes beyond the negative feedback technique

Unless you're using one of a small breed of fairly exotic tube amplifiers, chances are that your amplifier relies heavily on negative feedback for expanding frequency response, for reducing noise

and distortion, and for matching input and output impedances. But what you're probably not aware of is that as frequency increases, negative feedback loses its effectiveness.

Is there a way to extend the benefits of negative feedback to the higher audible frequencies and beyond? Five years ago, Sansui engineers hit upon the idea of trying the feedforward theory. In brief, the feedforward technique derives an error correcting signal—identical in level but reverse in phase to distortion components present at the output—from the amplifier itself. This signal is combined with the output signal and all distortion components are immediately cancelled. In the Sansui Super Feedforward System, a feedforward circuit is combined with a negative feedback circuit to form a formidable front line to fight noise and distortion. You can enjoy all the benefits in Sansui's new AU-D33 and AU-D22 integrated amplifiers.

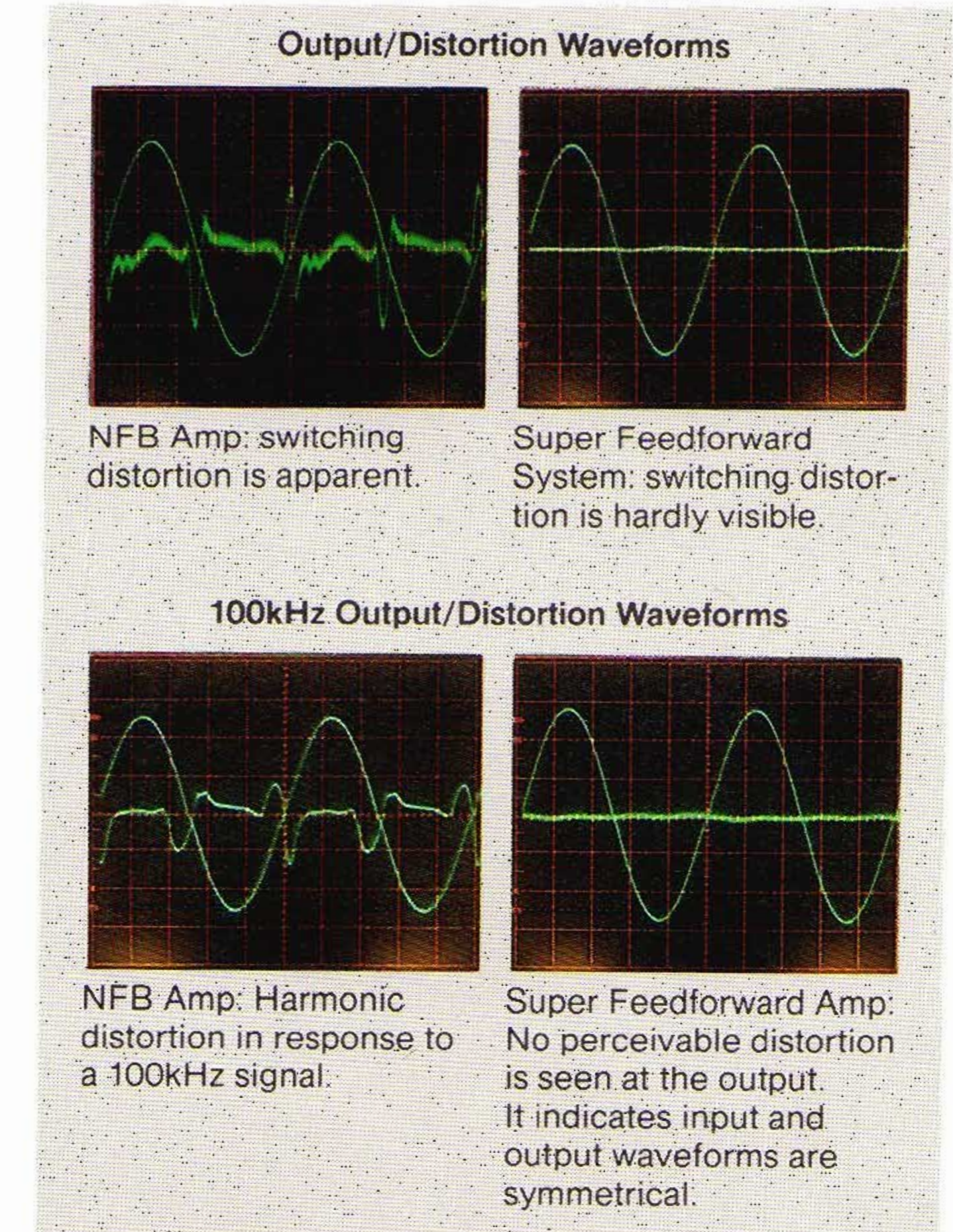

The Super Feedforward System plus DC configuration

If you are technically curious, here's a description of the circuit configuration of the AU-D33's power amp: the differential input consists of low-noise Dual-FETs, followed by a current differential cascode circuit with current mirror and then by a bootstrapped push-pull driver. The

final output stage is a 3-stage Darlington-connected DC configuration. The AU-D22's power amp is identical to the AU-D33's except that the differential input utilizes transistors.

Match such advanced and intricate circuits to the Super Feedforward System and you have a power amp that's hard to beat. In terms of power output, the AU-D33 offers 50 watts per channel, min. RMS, both channels driven into 8 ohms, from 20 to 20,000Hz with no more than 0.004% total harmonic distortion. The rated output of the AU-D22 is 35 watts per channel at 0.006% total harmonic distortion, measured under the same operating conditions.

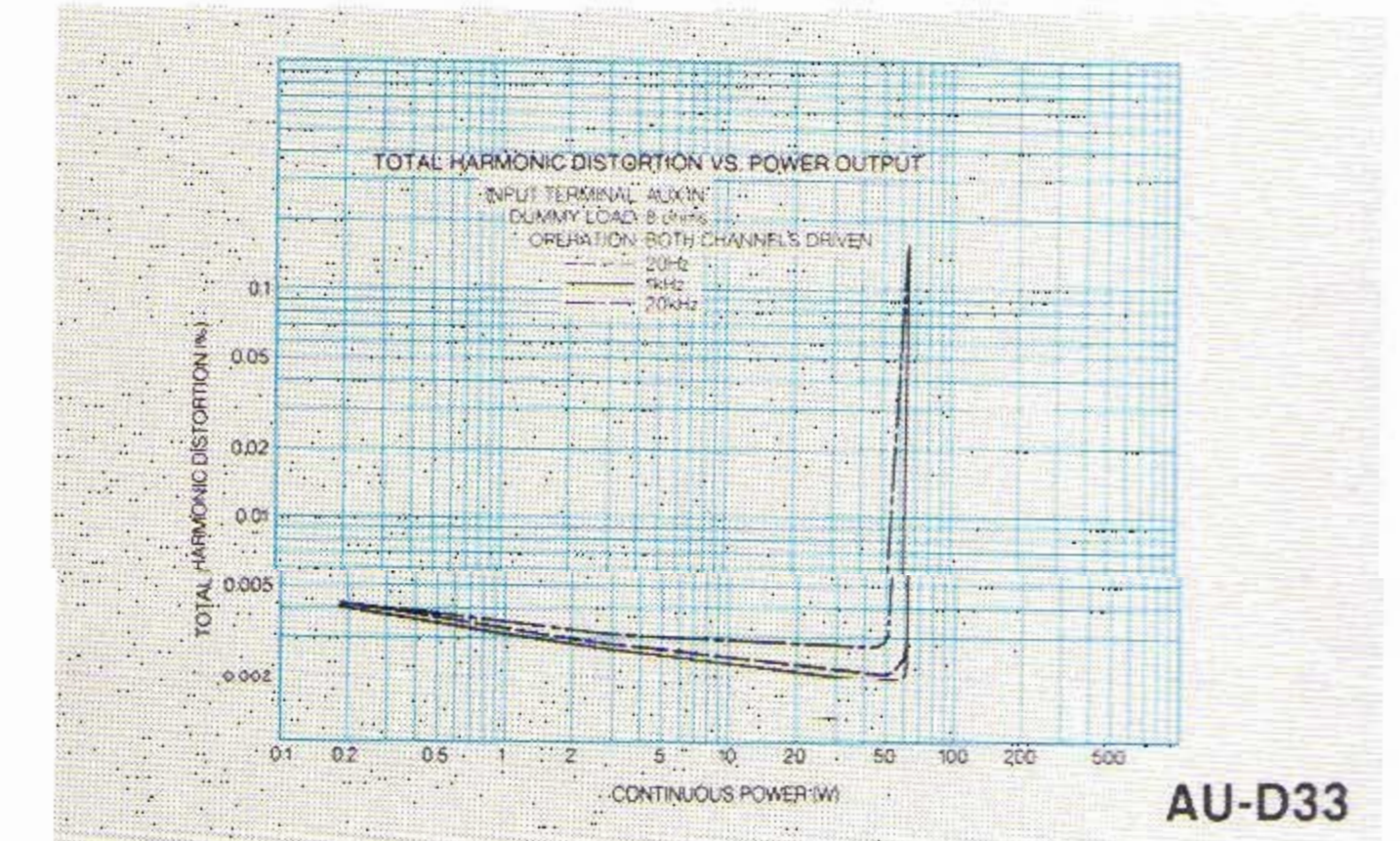

Dual-bridge Rectifier Circuit produces more powerful sounds than rated power

Though you get 50 watts and 35 watts of power per channel from the AU-D33 and AU-D22, respectively, you will notice that each sounds much more powerful. The reason lies in the design of the power supply; it employs a newly designed Dual-bridge Rectifier Circuit. Using four diodes instead of two per pole, it has reduced power consumption loss by

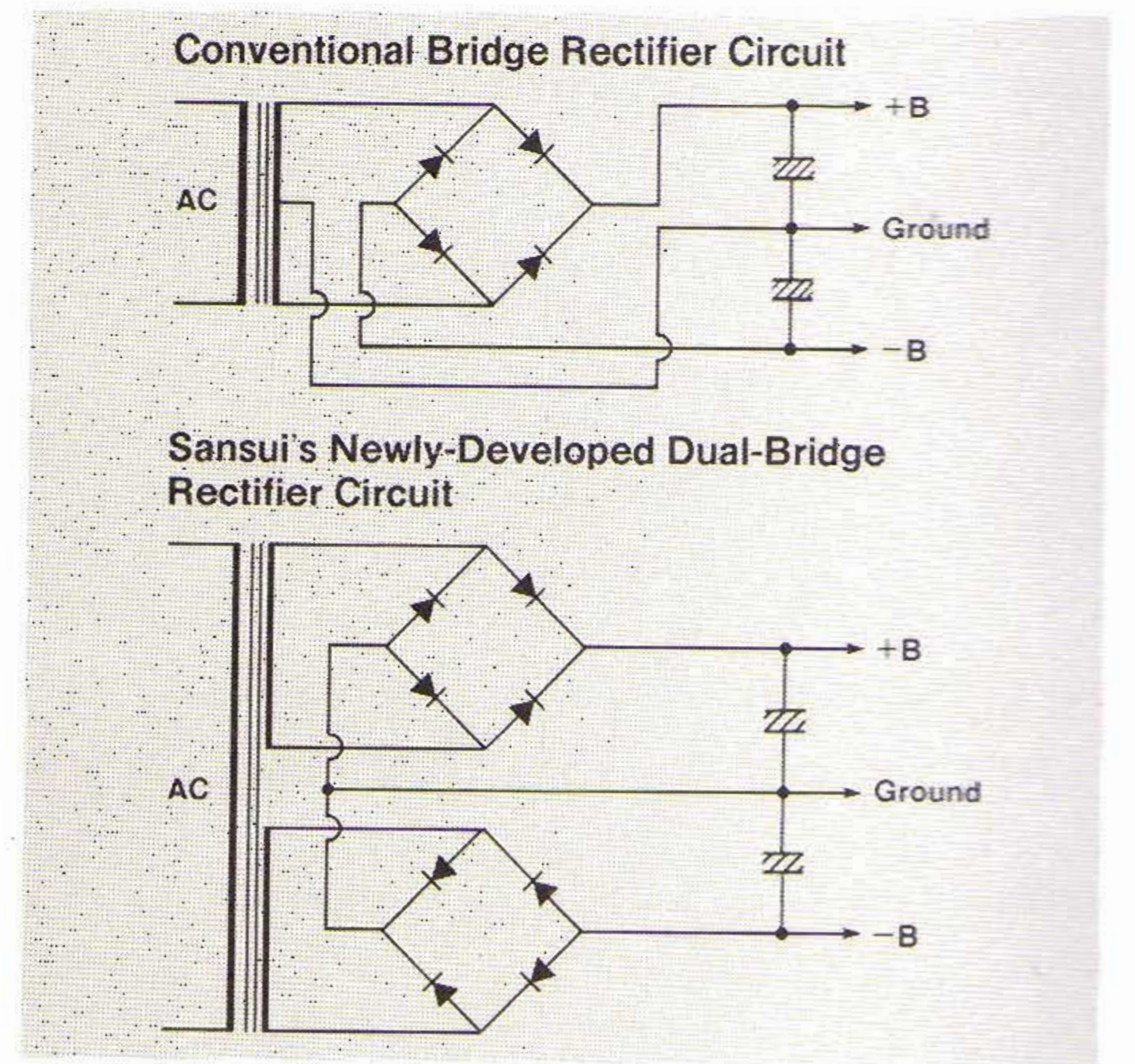

30 percent, thereby improving efficiency by that much. The result is more useful power than the specifications of either amplifier suggest.

This new power supply design offers yet another benefit. The power transformer is not directly grounded to the chassis, but instead is isolated by means of diodes. This reduces "stray currents," which in turn leads to better defined sonic imaging.

Ultra-wide range (20Hz to 100kHz) phono equalizer

The power amp of the AU-D33 and AU-D22 is matched with an equally capable phono equalizer that retains +0.2, -0.5dB RIAA playback accuracy all the way from 20Hz to an amazing 100kHz. What are the consequences of such unusual accuracy? For one, the wide dynamic range of high-quality records and cartridges is passed onto the power amp without a bit of limiting. For another, it reproduces music as it is, without adding audible coloration.

Simple and straight-forward two-amp construction

Inside the AU-D33 and AU-D22 are but two amps—the phono equalizer/amplifier and the power amp. There is no tone control amp. Instead, a defeatable tone control network is incorporated into the negative feedback loop of the power amplifier. The advantage of this simple configuration is that the input signal passes through only a minimum number of amplification stages, thereby retaining its purity until it ultimately reaches your ears via the speakers.

And the chassis layout is designed in such a way that wire lengths are kept as short as technically possible, and the heat sink is located between the driver and power output stages, serving as a kind of shield. All of this is done, of course, to retain sonic purity.

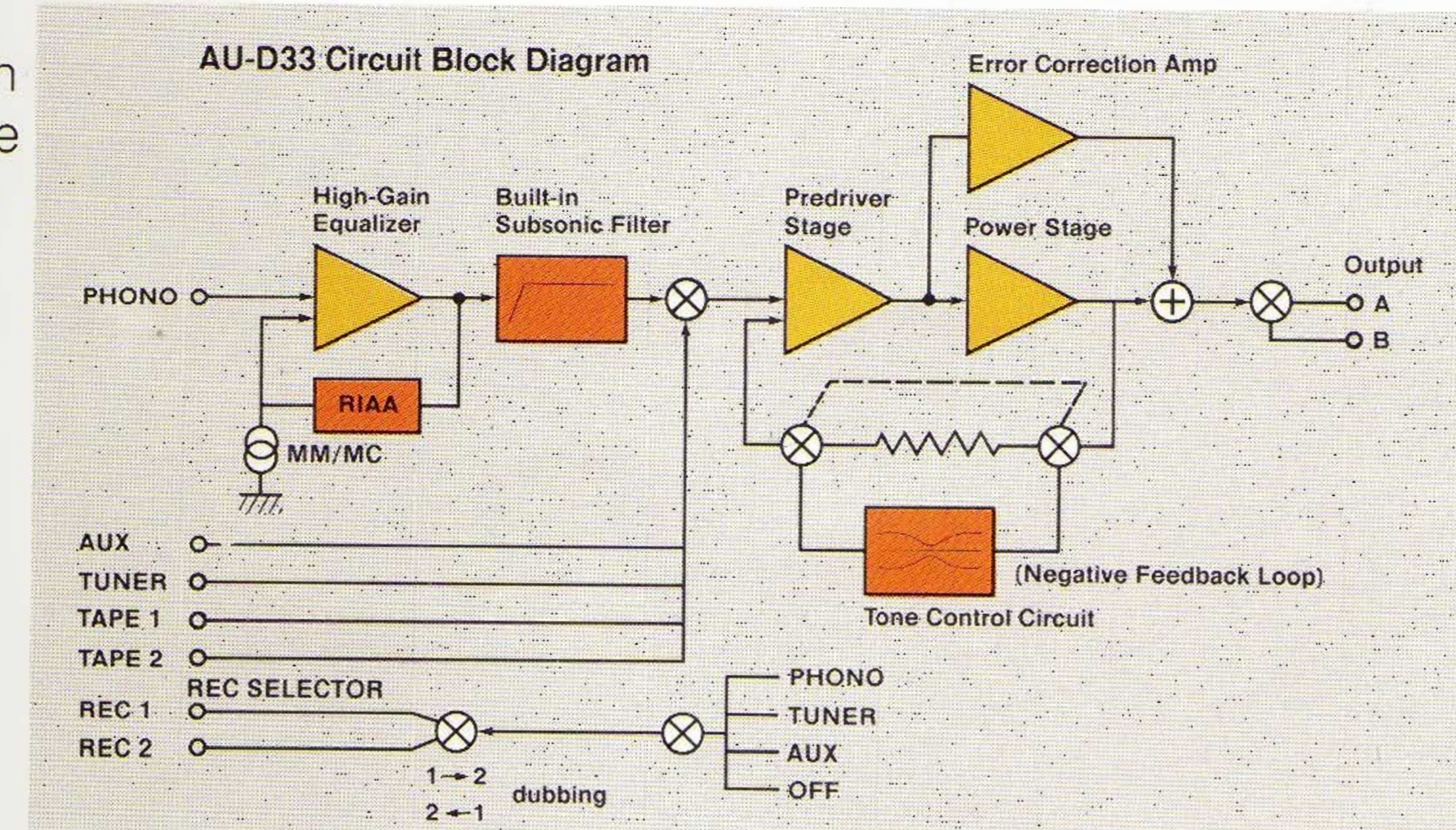

Protection circuits fully guard against speaker damage

Both the AU-D33 and AU-D22 feature a newly-developed current limiter circuit which, in the event of disturbed DC offset voltage or speaker cable shorting, automatically disconnects the speakers from the power amp, thus preventing excessive current from overloading—and damaging—the speakers. An indicator on the front panel flickers when the protection circuit activates.

A complement of controls for easy and convenient operation

- Direct Access Inputs—Direct access to any input program (PHONO, TUNER, AUX, TAPE 1 and TAPE 2) is possible. An LED indicator is located beside each input selector.
- Record Selector—One program source can be fed to a connected recorder while you are listening to another. The selector also offers positions for bidirectional tape dubbing (Tape 1 to 2, 2 to 1).
- MM/MC Phono Switches.
- Bass/Treble Tone Controls.
- Both models also offer: -20dB Muting, High Filter, and Speaker Selector Switches.

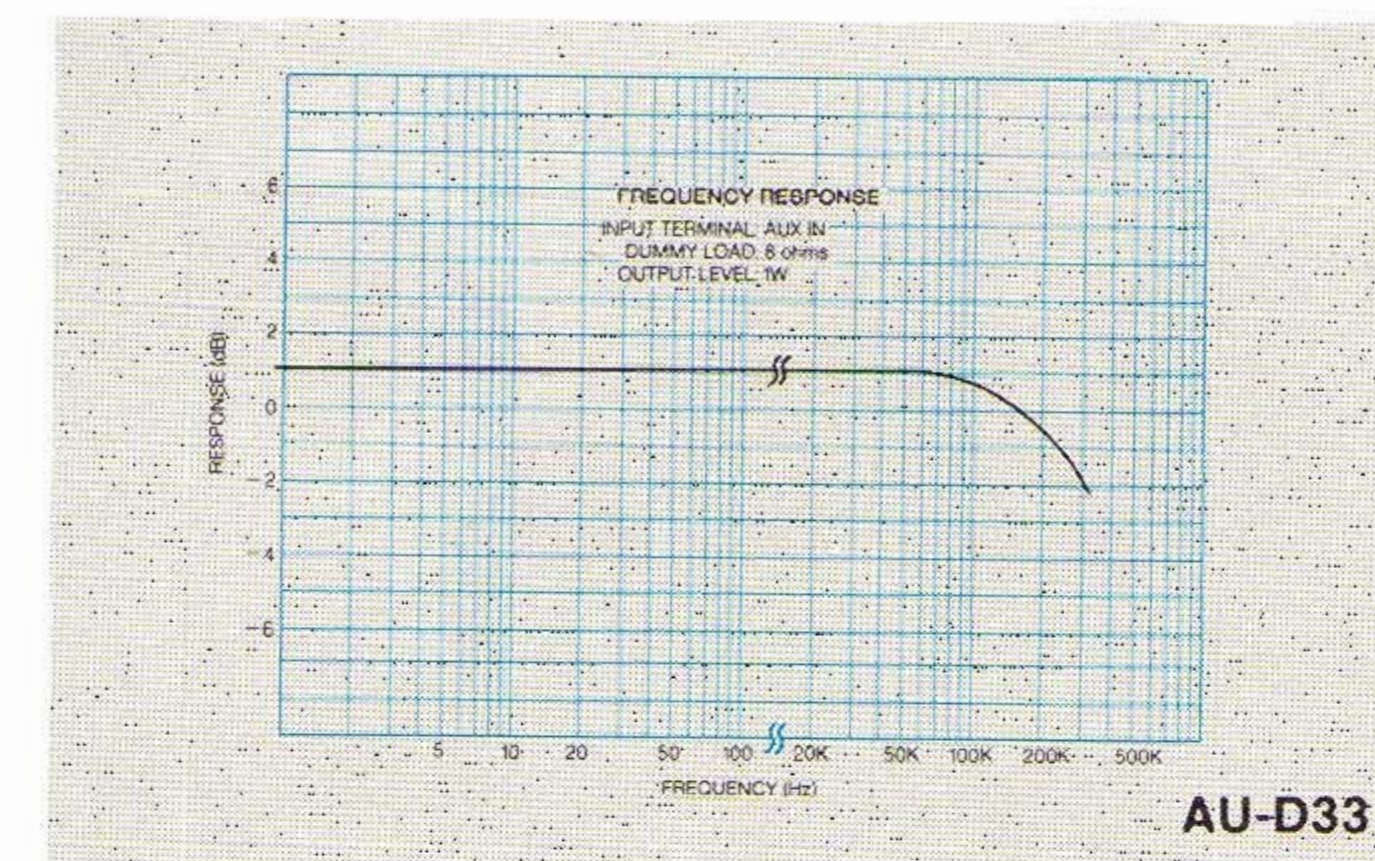

The TU-S33— Easy Tuning, Accurate Operation.

Servo-lock Tuning System for drift-free FM reception

It's not rare for a tuner to gradually drift out of tune due to changes in humidity and temperature. But the Servo-lock Tuning System of the TU-S33 does not let this happen; drift and tuning error are automatically detected and compensated for. Optimum reception quality is always assured. Here's how it works. When tuning error is detected, the Servo-lock system feeds the error back to the variable capacitance diode in the oscillator of the front end, so that the tuned frequency is again locked to the accurate local oscillator frequency. This assures stable reception.

Floating Circuit System (pat. pend.) for AM lessens noise

This is a new circuit, some design features of which we've borrowed from professionals: professional equipment is connected through balanced inputs and outputs to minimize noise. In a tuner, external noise may be picked up by the FM antenna and connection cables, and may be passed on to the chassis and ultimately to the AM front end. We make the FM antenna circuit and the output balanced, that is, floating (hence the name), so that AM signals are not contaminated by such noise. This is a feature you'll particularly appreciate during your everyday listening. You probably won't believe that AM can sound so quiet.

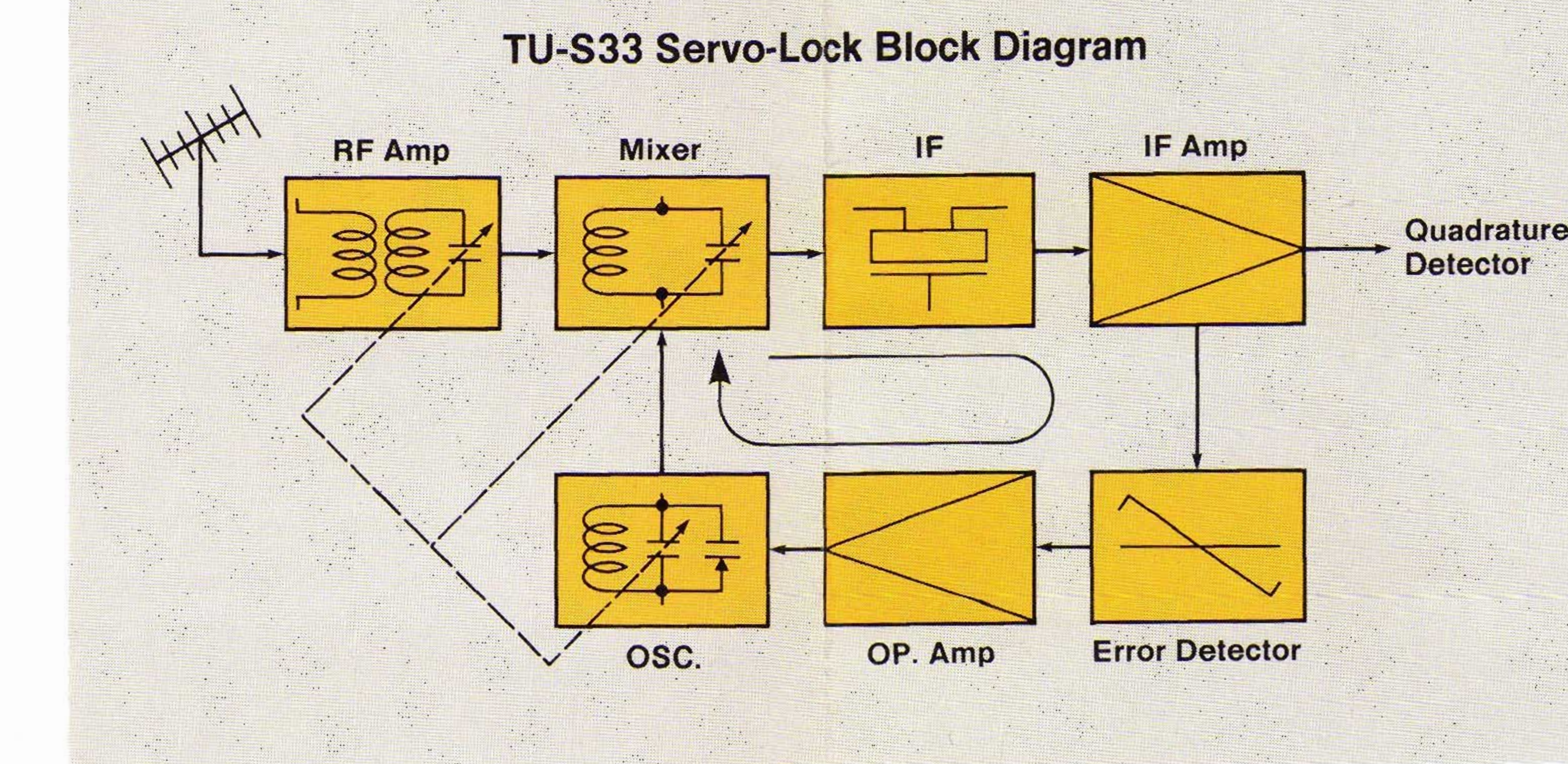

"Just Tuned" Pointer/Indicator for easy FM tuning

No longer does the tuning indicator need to be separated from the tuning pointer. In the TU-S33, we've integrated the two together. As you twirl the tuning knob and near an FM station, one of the arrow-shaped indicator LEDs to the left or right of the pointer will light, showing the direction you should continue turning

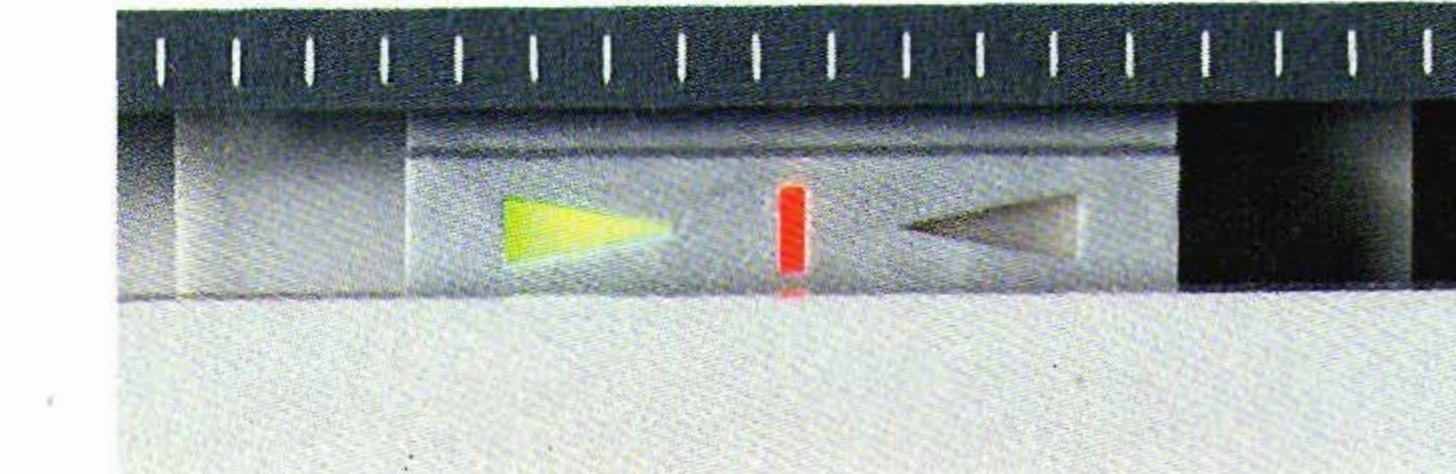

As you near a station, the left (or right) LED turns on.

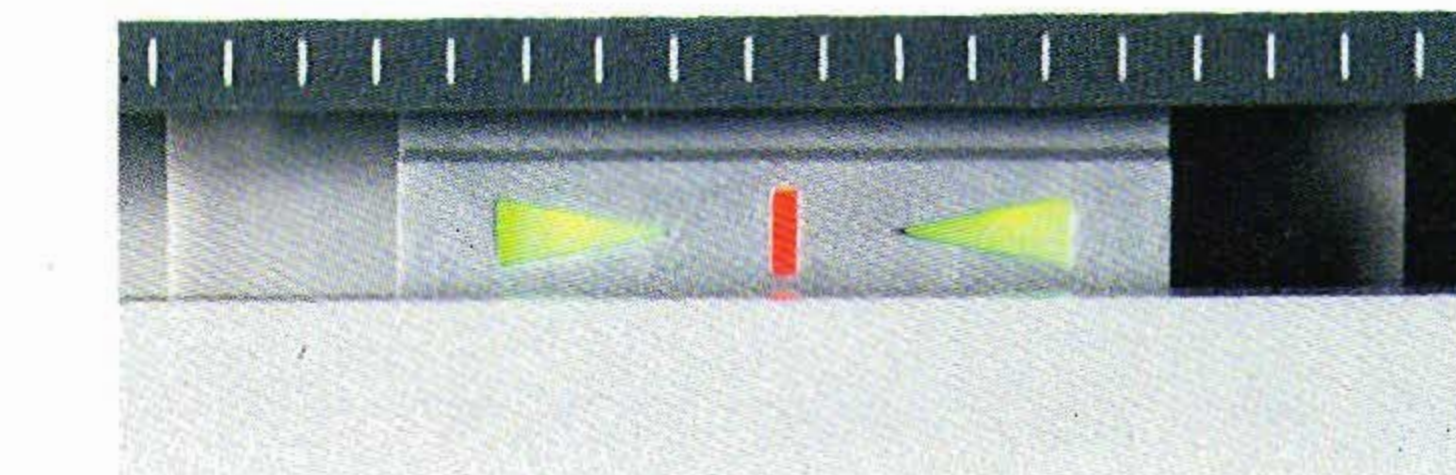

When the station is optimally tuned, both the left and right LEDs are on.

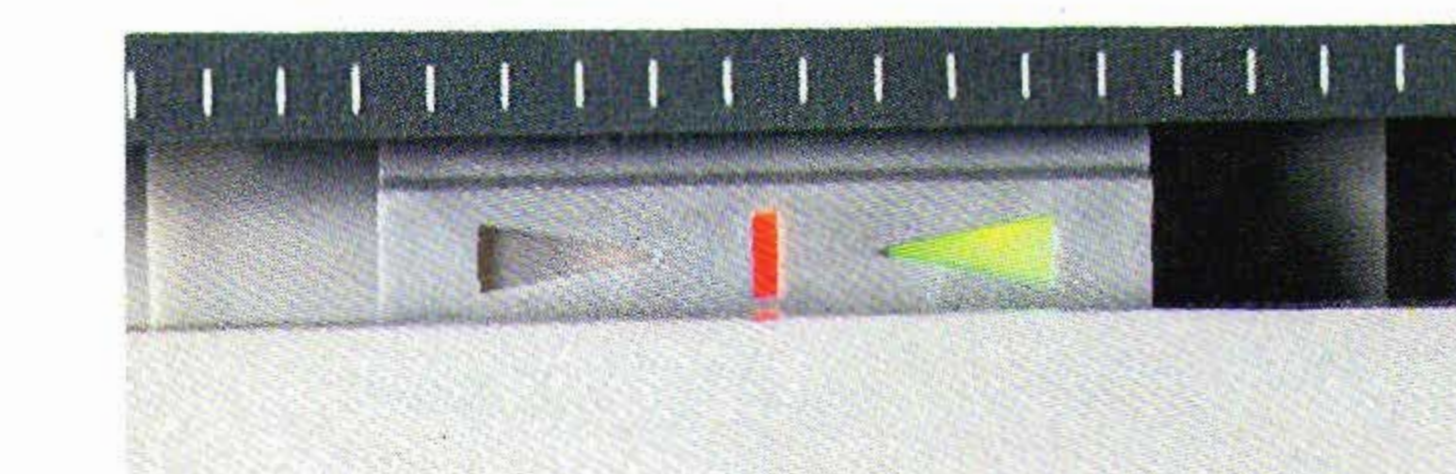

When you are over the exact tuning point, the right (or left) LED turns on.

the knob. When the station becomes optimally tuned, both arrows light. Tuning has never been so easy and accurate.

Top-flight specs include 10.8dBf sensitivity, 82dB signal-to-noise ratio (FM mono), and 50dB channel separation (1kHz)

The FM front end combines a low-noise junction-FET, a 3-gang variable capacitor and a high-Q tuning coil to effectively reject interference and increase sensitivity to 10.8dBf. It is followed by a double-tuned quadrature detector and a PLL (Phase-Locked Loop) multiplex demodulator that together make possible a high signal-to-noise ratio of 82dB (mono) and wide stereo separation of 50dB at 1kHz. Your favorite FM stations have never sounded better or clearer.

AM loop antenna shuts noise out

The TU-S33 incorporates a noise-resistant loop antenna for AM reception. Unlike a conventional bar antenna, this loop antenna is immune to interference noise generated by TV receivers, refrigerators and car. It's so sensitive that reception will be strong and clear even in concrete buildings.

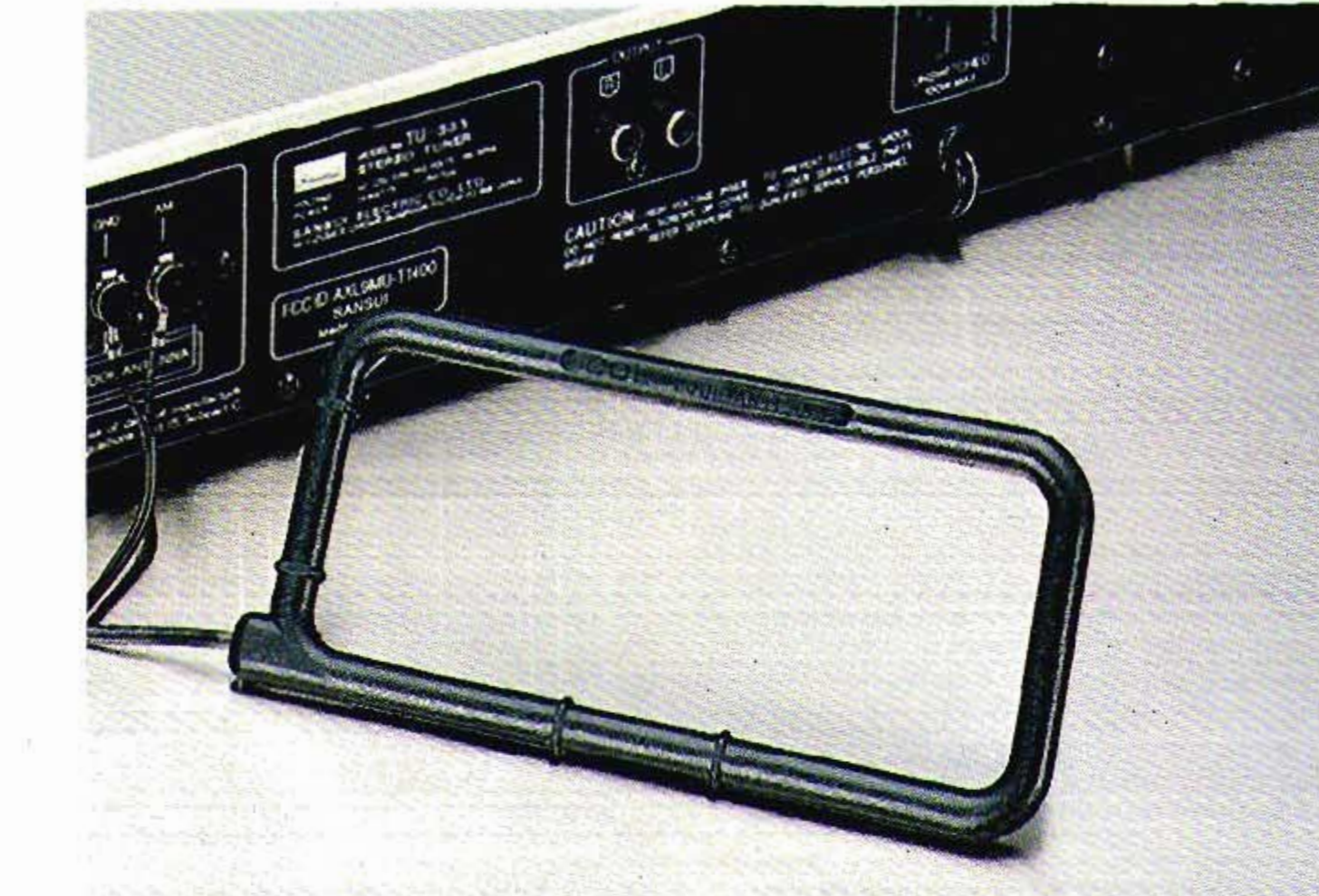

Other features

- FM Noise Canceller—High-frequency noise is cut with this circuit for better reception quality of weak-signal stereo

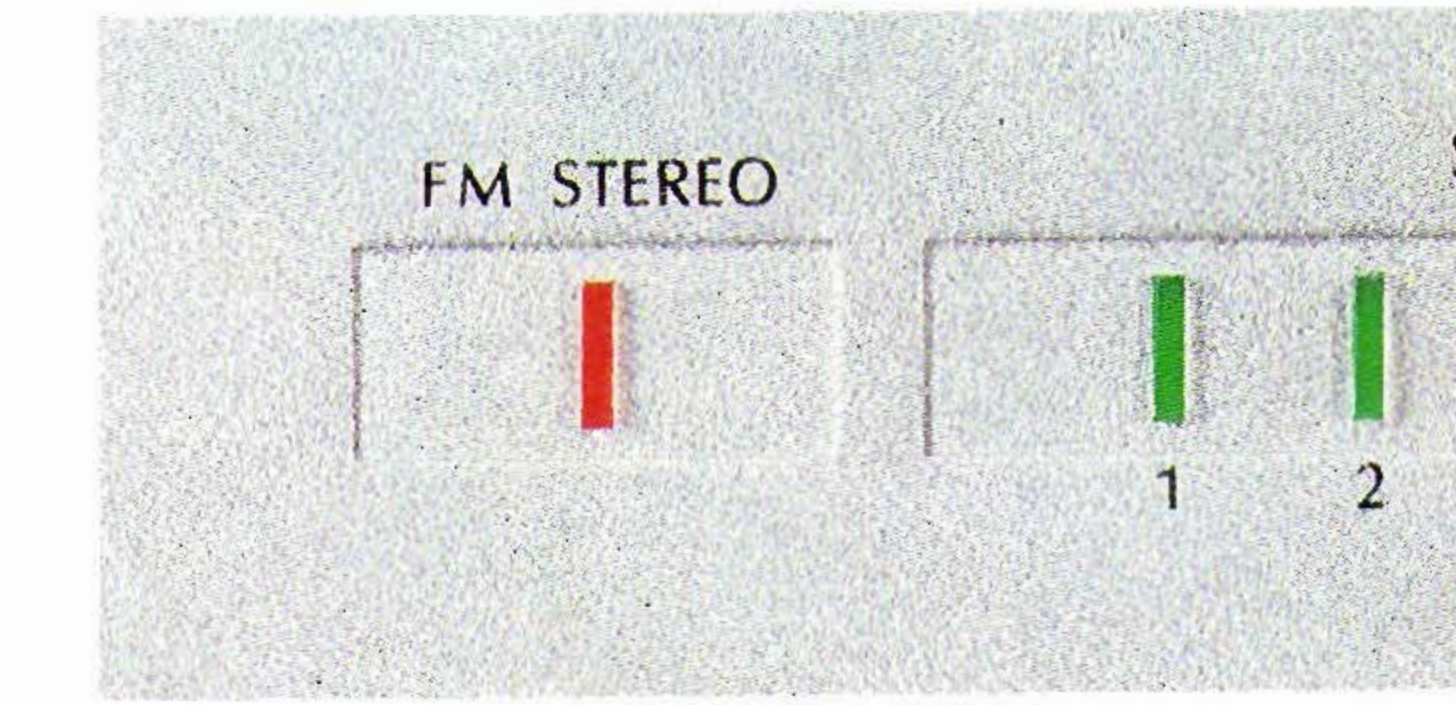

broadcasts. (Not incorporated in long-wave version TU-S33L).

- Muting/Mode Switch—In the stereo mode, irritating inter-station noise is eliminated by a built-in muting circuit. When set to the mono mode, muting is off, allowing the tuning in of weak-signal stations.

- G-LED Signal Strength Meter—Signal strengths of both FM and AM stations are shown in five discrete steps.

- LED FM Stereo Indicator.
- LED "Servo-Lock" Indicator. In European areas, a long-wave equipped version (TU-S33L), finished in black, is available.

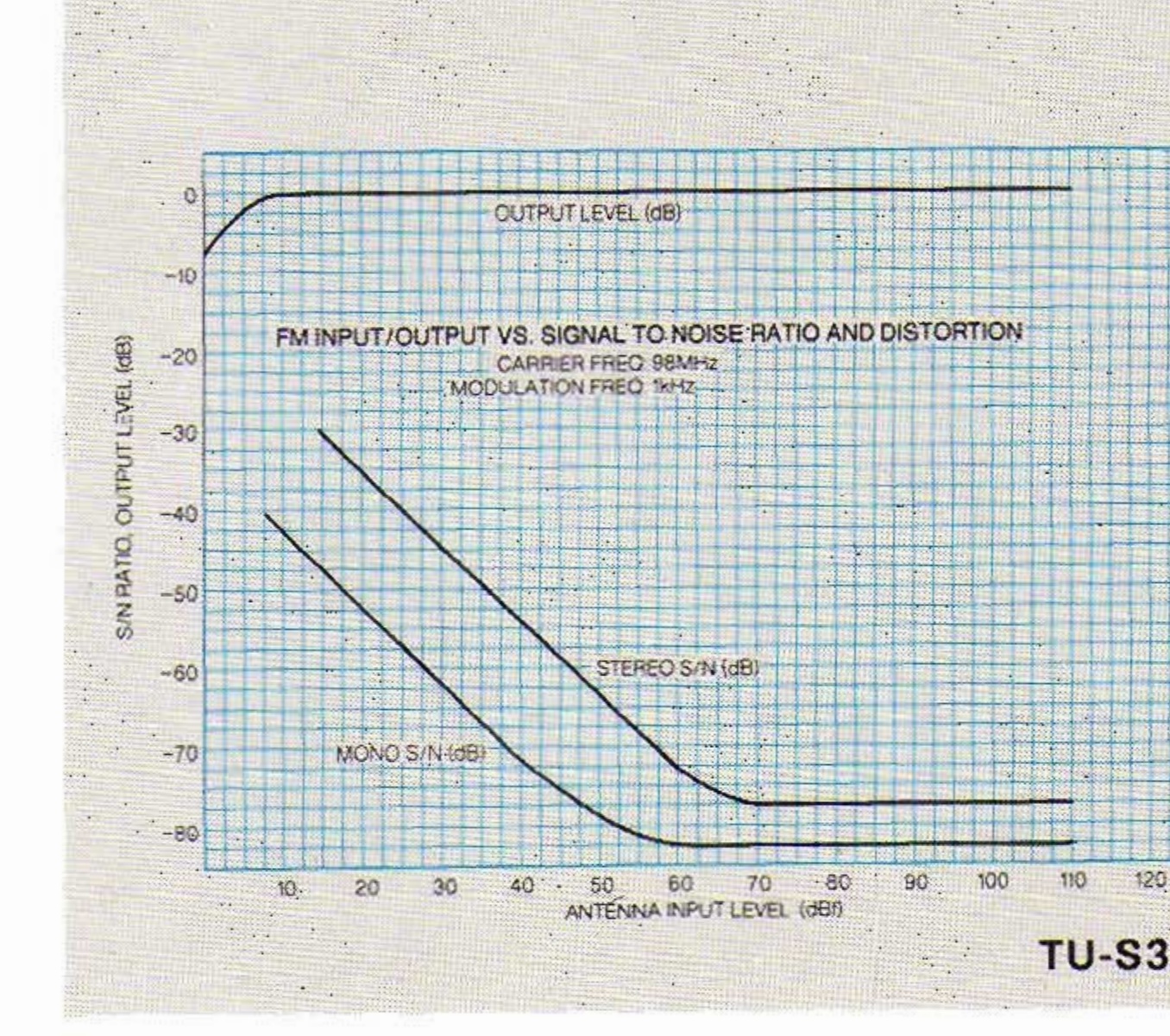
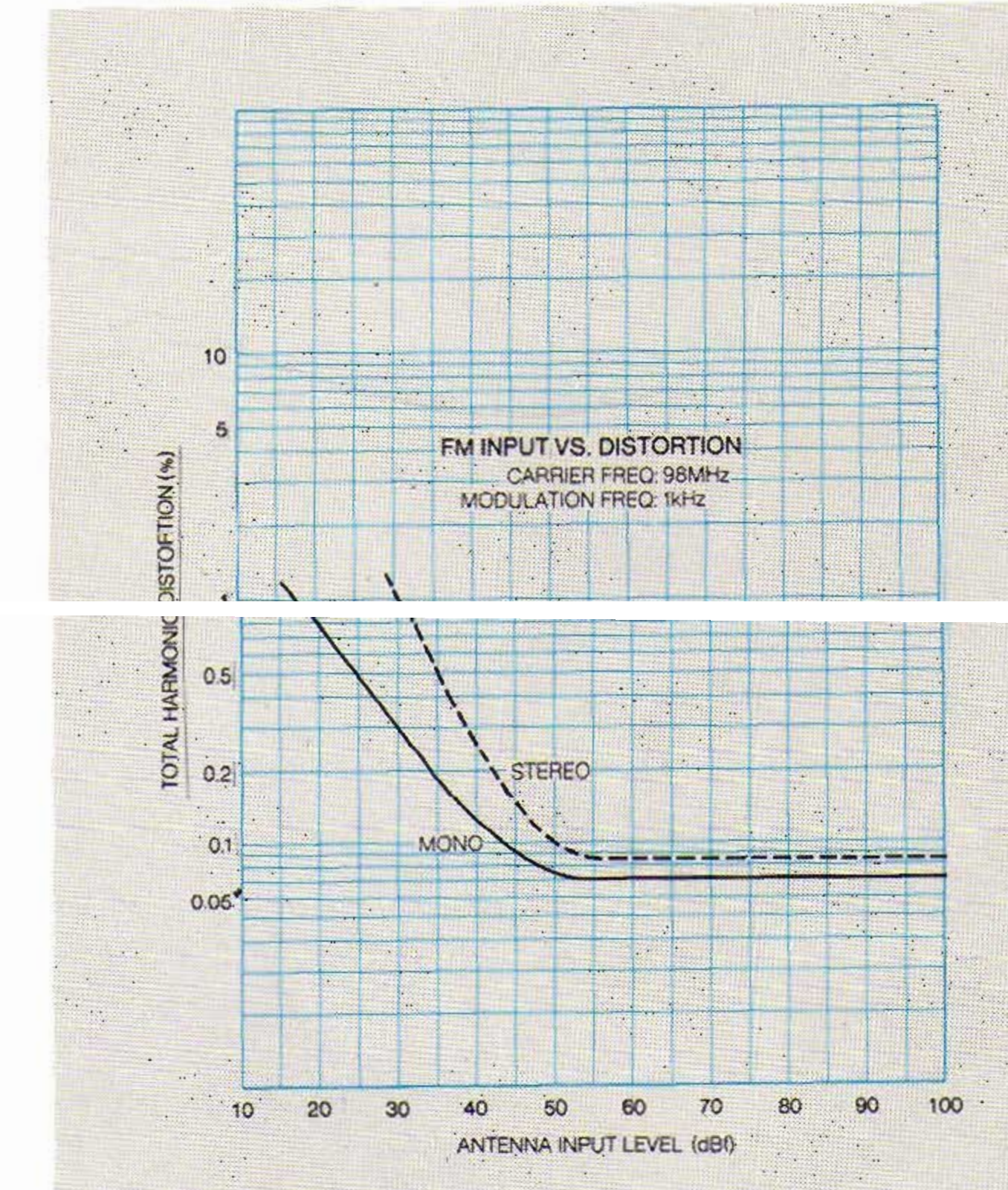

OF DISTORTION DISPUTES.

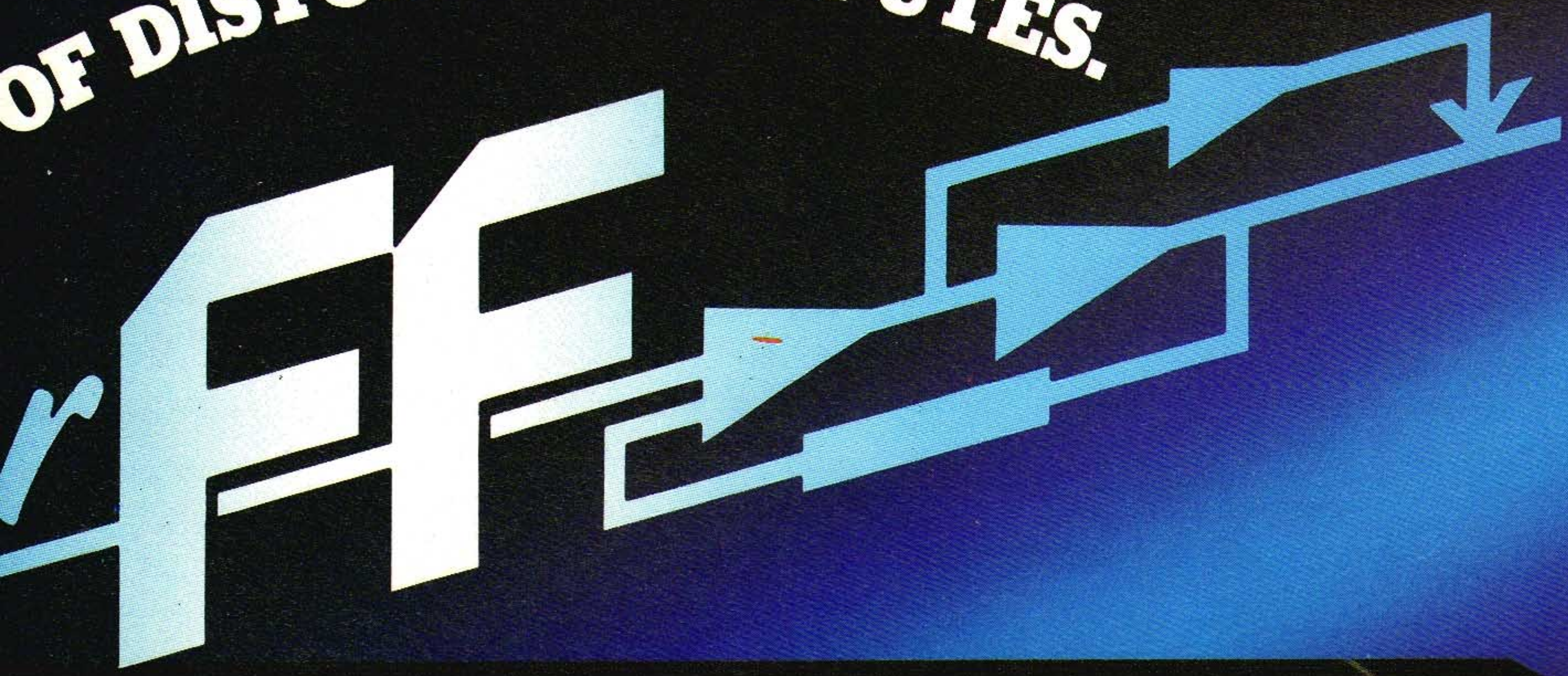

Specifications

AU-D33

POWER OUTPUT*

Min. RMS, both channels driven, from 20 to 20,000Hz, with no more than 0.004% total harmonic distortion 50 watts per channel into 8 ohms

LOAD IMPEDANCE*

8 ohms

TOTAL HARMONIC DISTORTION*

OVERALL (from AUX) less than 0.004% at or below rated min. RMS power output

INTERMODULATION DISTORTION (60Hz: 7,000Hz=4:1 SMPTE method)

less than 0.006% at or below rated min. RMS power output

DAMPING FACTOR (at 1,000Hz, both channels driven)

40 into 8 ohms

SLEW RATE

±150V/μSec.

RISE TIME

0.9μSec.

FREQUENCY RESPONSE (at 1 watt)

OVERALL (from AUX) DC to 300,000Hz +0dB, -3dB
PHONO (MM) 20 to 100,000Hz +0.2dB, -0.5dB

RIAA CURVE DEVIATION (20 to 20,000Hz)

+0.2dB, -0.2dB

INPUT SENSITIVITY AND IMPEDANCE (at 1,000Hz)

PHONO 2.5mV, 47k ohms (MM), 250μV, 100 ohms (MC)
AUX, TUNER, TAPE 200mV, 47k ohms

MAXIMUM INPUT CAPABILITY (at 1,000Hz 0.01% MM, 0.1% MC)

PHONO 170mV RMS (MM), 12mV RMS (MC)

OUTPUT VOLTAGE AND IMPEDANCE (at 1,000Hz)

TAPE REC 200mV/600 ohms into 47k ohm load

HUM AND NOISE (IHF A)

PHONO 84dB (MM), 65dB (MC)
AUX 105dB

CHANNEL SEPARATION (at 1,000Hz)

PHONO 72dB
AUX 90dB

CONTROLS

BASS +10dB, -10dB at 50Hz
TREBLE +10dB, -10dB at 10kHz
LOUDNESS (volume control at -30dB position)

+8dB at 100Hz

+5dB at 10kHz

HIGH FILTER -3dB at 10kHz (6dB/oct.)

AUDIO MUTING -20dB

AC OUTLETS

switched max. 100 watts
unswitched total 300 watts

POWER REQUIREMENTS

POWER VOLTAGE 120, 220, 240V 50/60Hz
POWER CONSUMPTION 210 watts

DIMENSIONS

430mm (16¹⁵/₁₆"W)
112mm (4⁷/₁₆"H)
334mm (13³/₁₆"D)
7.3kg (16.1 lbs.) Net
8.3kg (18.3 lbs.) Packed

AU-D22

POWER OUTPUT*

Min. RMS, both channels driven, from 20 to 20,000Hz, with no more than 0.006% total harmonic distortion 35 watts per channel into 8 ohms

LOAD IMPEDANCE*

8 ohms

TOTAL HARMONIC DISTORTION*

OVERALL (from AUX) less than 0.006% at or below rated min. RMS power output

INTERMODULATION DISTORTION (60Hz: 7,000Hz=4:1 SMPTE method)

less than 0.007% at or below rated min. RMS power output

DAMPING FACTOR (at 1,000Hz, both channels driven)

40 into 8 ohms

FREQUENCY RESPONSE (at 1 watt)

OVERALL (from AUX) 20 to 300,000Hz +0dB, -3dB
PHONO 20 to 100,000Hz +0.2dB, -0.5dB

RIAA CURVE DEVIATION (20 to 20,000Hz)

+0.2dB, -0.2dB

INPUT SENSITIVITY AND IMPEDANCE (at 1,000Hz)

PHONO 2.5mV, 47k ohms (MM), 250μV, 100 ohms (MC)
AUX, TUNER, TAPE 200mV, 47k ohms

MAXIMUM INPUT CAPABILITY (at 1,000Hz 0.01% MM, 0.1% MC)

PHONO 170mV RMS (MM), 12mV RMS (MC)

OUTPUT VOLTAGE AND IMPEDANCE (at 1,000Hz)

TAPE REC 200mV/600 ohms into 47k ohm load

HUM AND NOISE (IHF A)

PHONO 84dB (MM), 65dB (MC)
AUX 105dB

CHANNEL SEPARATION (at 1,000Hz)

PHONO 60dB
AUX 90dB

CONTROLS

BASS +10dB, -10dB at 50Hz
TREBLE +10dB, -10dB at 10kHz
LOUDNESS (volume control at -30dB position)

+8dB at 100Hz

+5dB at 10kHz

HIGH FILTER -3dB at 10kHz (6dB/oct.)

AUDIO MUTING -20dB

AC OUTLETS

switched max. 100 watts
unswitched total 300 watts

POWER REQUIREMENTS

POWER VOLTAGE 120, 220, 240V 50/60Hz
POWER CONSUMPTION 160 watts

DIMENSIONS

430mm (16¹⁵/₁₆"W)
112mm (4⁷/₁₆"H)
334mm (13³/₁₆"D)
6.8kg (15.0 lbs.) Net
7.8kg (17.2 lbs.) Packed

WEIGHT

TU-S33

FM SECTION

TUNING RANGE

88 to 108MHz

50dB QUIETING SENSITIVITY

MONO 16.5dBf
STEREO 36.5dBf

SENSITIVITY

MONO (IHF) 10.6dBf (1.85μV IHF T-100)

SIGNAL TO NOISE RATIO

MONO 81dB (at 65dBf)
STEREO 76dB (at 65dBf)

FREQUENCY RESPONSE

STEREO 30 to 15,000Hz +0.3dB, -1.0dB

TOTAL HARMONIC DISTORTION

MONO less than 0.08% at 100Hz
less than 0.08% at 1,000Hz
less than 0.08% at 6,000Hz
STEREO less than 0.09% at 100Hz
less than 0.09% at 1,000Hz
less than 0.09% at 6,000Hz
1.0dB

CAPTURE RATIO

ALTERNATE CHANNEL SELECTIVITY

60dB (at 400kHz)

SPURIOUS RESPONSE RATIO

75dB

IMAGE RESPONSE RATIO

50dB

IF RESPONSE RATIO

85dB (Balanced)

RF INTERMODULATION RATIO

60dB

AM SUPPRESSION RATIO

65dB

STEREO SEPARATION

50dB at 1,000Hz

ANTENNA INPUT IMPEDANCE

300 ohms balanced, 75 ohms unbalanced

OUTPUT VOLTAGE AND IMPEDANCE

FIXED 0.5V, 2.2k ohms

AM SECTION

TUNING RANGE

530 to 1,600kHz [LW: 150 to 350kHz]

SENSITIVITY (Loop Antenna)

56dB/m (630μV/m) [LW: 58dB/m (794μV/m)]

SELECTIVITY (±9kHz)

30dB

SIGNAL-TO-NOISE RATIO

45dB

TOTAL HARMONIC DISTORTION

less than 0.5% at 30% Mod. 80dB/m

IMAGE RESPONSE RATIO

45dB at 1,000Hz [LW: 30dB/m at 250kHz]

GENERAL

POWER

POWER VOLTAGE 120, 220, 240V, 50/60Hz [LW: 220, 240V, 50Hz]
POWER CONSUMPTION 14 watts

AC OUTLET

unswitched total 100 watts

DIMENSIONS

430mm (16¹⁵/₁₆"W)
76mm (3"H)
272mm (10³/₄"D)
3.5kg (7.7 lbs.) Net
4.5kg (9.9 lbs.) Packed

WEIGHT

*Power specifications measured pursuant to U.S. Federal Trade Commission trade regulations on power output claims for amplifiers.

Design and specifications subject to change without notice for improvements.



SANSUI ELECTRIC CO., LTD.

14-1 IZUMI 2-CHOME, SUGINAMI-KU, TOKYO 168 JAPAN/TELEX: 232-2076

SANSUI ELECTRONICS CORPORATION

1250 VALLEY BROOK AVENUE, LYNDHURST, NEW JERSEY 07071, U.S.A./TELEX: NEW JERSEY 422633 SEC UI

SANSUI ELECTRONICS (U.K.) LTD.

UNIT 10A, LYON INDUSTRIAL ESTATE, ROCKWARE AVENUE, GREENFORD, MIDDX UB6, OAA, ENGLAND/TELEX: 895 2103 (SANSUI G)